

ΦTensil

Fiam Electric Tightening Solutions

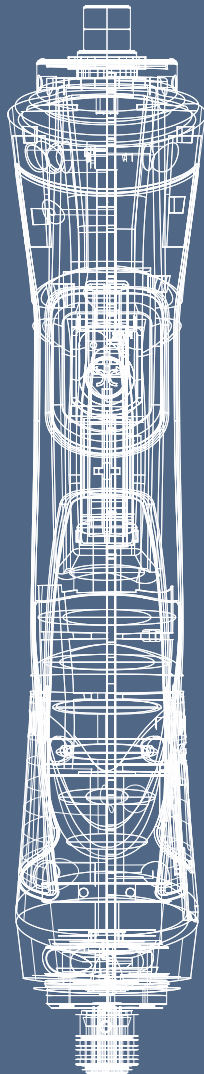

Electric tightening solutions with torque/angle current control:
screwdrivers, nutrunner motors and solutions for automation.
Control units with advanced programming.



eTensil. Fiam's electrical revolution continues.

With eTensil, Fiam sets the benchmark in the world of industrial tightening. We have integrated our tried-and-tested air solutions with a range designed and manufactured to raise the level in manual and automatic tightening through **electric tools with torque/angle current control**. Nowadays the components to be assembled include several variants which, besides different geometries, are designed for different types of screws and torque values. Therefore a **complete production flexibility which involves the use** of efficient, versatile and smart tools is needed. eTensil new range meets these requirements thanks to its **torque/angle control current system, which ensures a great productive versatility**.

Electric, efficient and accurate, eTensil is the Italian made response to this modern industry's demand for green, versatile and intelligent tools. We have designed them to be integrated in smart production: **from precision mechanics to automotive, from electronics to household appliances assembly**. Design, power, manufacturing precision are the cornerstones making eTensil a proud Italian solution. A consistent project in which every detail has been taken into account aiming at top performance.

Control units with advanced programming

p. 4



Manual tightening systems

p. 8



Ergonomics and position monitoring devices

p. 20

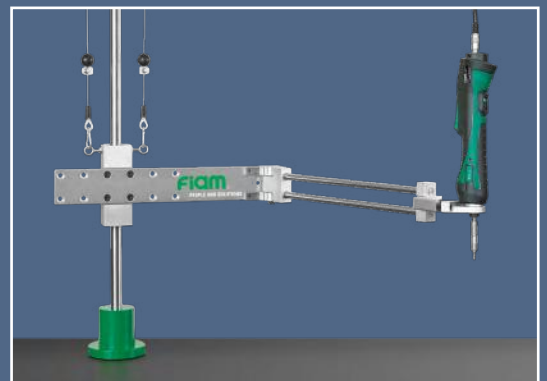

Automatic tightening systems

p. 24



Control units. Smart power.

The control units of this new range represent the real **great innovation of the whole project. Thanks to their “smart core” the control units can program, control and manage all the tools functions.**

Designed and built entirely by Fiam, they represent a strategic choice providing one of the most advanced solutions in terms of efficiency and versatility for the industrial production.

1. Two control units with common features. TPU-C1 and TPU-C3 models.

The two units are
- TPU-C1, basic model
- TPU-C3 advanced model
with a fast and intuitive programming, they offer **essential functions to correctly and quickly manage a tightening process** and make it reliable:

AUTOMATICALLY AND IMMEDIATELY RECOGNIZING THE CONNECTED TOOL

and setting the applicable parameters range for it.

ALLOW IN-PROCESS TORQUE ADJUSTMENTS

by modifying the relevant parameter on the operating panel.

SCREW COUNTING

this function turns the system into an effective Poka Yoke device.

The tightening results are visualized on the unit display, highlighted by the leds.

STORING

the outcome of the last 99 tightening.

CHECK TIGHTENING TIME

to detect process anomalies like over-treading and already tightened screws.

COMMUNICATION WITH MASTER PLC

and others devices: **8 + 8 signals I/O** freely programmable that offer several functionalities to be chosen from 9 + 11 signals (TPU-C1) and 21 + 22 signals (TPU-C3).
Allow to communicate:

- outcome of a phase
- system status
- the remote control of the tool.

DISPLAYING OF TIGHTENING RESULTS

TPU-C1 model:

- OK/ NOK status
- torque value in Nm or other unit of measurement
- tightening time value

TPU-C3 model:

- OK/ NOK status
- torque value in Nm in Nm or other unit of measurement
- tightening time value
- angle value.

INTERFACING WITH WORKING STATIONS

In presence of Jigs, workpieces locking devices can be activated/deactivated.

“SMART THREAD” FUNCTION

for processing of self-threading, self-tapping, self-drilling screws, or else where the **final torque value is lower than thread forming torque.**

“SMART SPEED” FUNCTION

useful for speeding up the production process. It is possible to create a “two-phase” tightening strategy:

- The first with a high-speed screwdriver rotation until reaching the set angle
- The second with a pre-defined speed that allows to maintain the accuracy of the result.

TPU-C1 control unit, basic model.



2. Exclusive “SMART PRO EVO” Programming.

eTensil is the unique screwdriver that allows changing the starting mode without modifying the mechanical configuration.

START UP MODES

can be set on the control unit:

- Lever start
- Push to start
- Lever start + Push to start
- “Latched lever” + Push to start.

Other functions can be activated / deactivated acting directly on the control unit

- **CONFIRMATION REQUESTED FOR ANOMALY** (by pressing ESC button)
- **CONFIRMATION REQUESTED FOR END OF CYCLE** (by press ENTER button)

- **UNTIGHTENING**
- **CLOCKWISE** or **COUNTERCLOCKWISE** tightening.

The main feature of these advanced units is the **possibility to set different control functions:**

- **SOFT START**
the ramp speed acceleration is not fixed but it is possible to set the **time** acceleration to ease screw engagement
- **TOOL SPEED**
can be set within the minimum / maximum range
- **MANAGEMENT OF ALLOWED ERRORS**
- **FRONT LED LIGHTING**
adjustable with intensity from 0 to 100%.

3. Functional design.

Functionality and aesthetics combine in the control unit design, allowing practical access to the operating panel. These features together with the **sturdiness** make this unit perfect for a vertical clamp.

4. Signaling LEDs.

The **high-visibility** LEDs, with adjustable intensity, placed above the display, allow immediate viewing of the process status.

For a synchronized and efficient tightening management:

- Red LED** = Nok
- Yellow LED** = End of cycle
- Green LED** = Cycle progress (screws tightened) according to the set number of screws.

Performance and functions. Advanced programming.

The advanced TPU-C3 control unit is equipped with all the features of the basic model. It guarantees the status control of the tool and of the assembly process with **additional programming features**.

The additional features of the advanced TPU-C3 model.

5. Programming.

Possibility to set up to **8 tightening programs with torque, angle and time control/monitoring**. The programs can be managed in sequence and can also be selected remotely in single mode or with binary combination, which allow to set both the number of screws and the torque/angle/time values.

6. Displaying all tightening parameters.

The advanced **TPU-C3 model displays the angle value at the end of each cycle** together with tightening time and torque values. To always keep the assembly process under control.

7. Monitoring of the tightening angle.

Another key difference comparing this unit with the basic version TPU-C1 is represented by this functionality. For example, **it can work as Poka Yoke system when tightening critical joints**. Should you have elastic gaskets, rubber elements or other materials, **the control unit verifies that these are present or not during the process**. This is made by measuring the angle and comparing it with a range set by the operator during the programming phase.

8. "SMART PRO EVO" functions.

Other additional settable features are:

- **PRE-AUTO UNTIGHTENING:** it is possible to set the **untightening angle and the pause between the untightening and the subsequent tightening**. This strategy finds its application in the electrical / electronic field, for example when it is necessary to open and then close connectors to insert electrical wires.
- **POST-AUTO UNTIGHTENING:** it is possible to set the **untightening angle** as the pause time between untightening and subsequent tightening.
- **STOP-BY-TIME TIGHTENING**
When it is necessary to tighten threaded fasteners to a certain **height and not to a defined torque**. This is made by checking the tightening time.

TPU-C3 control unit, advanced model.



The two control units compared

TPU-C1	TPU-C3
• 1 program to control tightening process	• 8 programs to control the tightening process
• Automatic recognition of the tool and configuration	• 1 programmable sequence up to a max of 8 steps
• Screw counter - Poka Yoke system	• Automatic recognition of the tool and configuration
• OK / NOK and torque value display in Nm or other unit of measurement	• Screw counter - Poka Yoke system
• "Smart Thread" function	• OK/NOK and torque value display in Nm or other unit of measurement
• "Smart Speed" function	• "Smart Thread" function
• Min / Max tightening time control - Poka Yoke system	• "Smart Speed" function
• Settable untightening speed	• Min / Max tightening time control - Poka Yoke system
• Clockwise or Counterclockwise tightening	• Settable untightening speed
• 2 levels password: to protect the set parameters or totally block the system	• Clockwise or Counterclockwise tightening
• Unit calibration	• 2 levels password: to protect the set parameters or totally block the system
• Available measurement units Nm / Lb / In. / Kgf.cm	• Unit calibration
• Serial communication (RS232)	• Available measurement units Nm / Lb / In. / Kgf.cm
• Language selection (IT, EN, DE, FR, ES)	• Serial communication (RS232)
• Log of the last 99 tightenings	• Language selection (IT, EN, DE, FR, ES)
• Interfacing with working stations	• Log of the last 99 tightenings
• 8 + 8 programmable I/O (9 + 11 signal types)	• Interfacing with working stations
SMART PRO EVO PROGRAMMING	• 8 + 8 programmable I/O (21 + 22 signal types)
- 4 start-up modes selectable on the unit	• Selection of programs from I / O (remotely)
- Soft Start - acceleration ramp	• Min / Max tightening angle control - Poka Yoke system
- Settable rotation speed	SMART PRO EVO PROGRAMMING
TIGHTENING STRATEGIES	- 4 start-up modes selectable on the unit
■ Torque control	- Soft Start - acceleration ramp
■ Torque control with tightening time monitoring	- Settable rotation speed
	• Pre-auto Untightening (can be activated with all tightening strategies)
	• Post-auto Untightening (can be activated with all tightening strategies)
	TIGHTENING STRATEGIES
	■ Torque control
	■ Torque control with tightening time monitoring
	■ Torque control with tightening angle monitoring
	■ Torque control with time and tightening angle monitoring
	■ Angle control and torque monitoring
	■ Time control and torque monitoring (Stop-by-time tightening)

Additional features of TPU-C3 compared to the basic unit are highlighted in red on the chart above

Production flexibility. Efficiency at hand.

The user can **manually programme various work processes on the tools themselves**, without having to change the mechanical setup or having to deal with an external accessory. This strategic choice defines eTensil as one of **the most advanced solutions in terms of efficiency and versatility**.

9. Torque/angle current control system.

This technology offers the possibility of **adjusting the torque during operation**. This can be done simply by changing the specific parameter on the control unit, which is the “smart core” of this range of solutions. In this system **the torque is detected by measuring the current used by the motor. The angle is detected through specific hall sensors**.

10. Signaling LEDs.

Three LEDs ensure precise and efficient signaling. It is a simple solution that ensures the screwdrivers’ settings and correct functioning are immediately apparent to the user. **The blue LED** near the reverse button remains lit to signal that the screwdriver is in “untighten” mode (leftwards rotation). **The white LED in the same area** shows the tool is ready for use. **The LED at the front**, next to the quick change chuck, lights up the area of work as well as indicating anomalous functioning at the end of a tightening cycle (in conjunction with the blue LED). Once the same LED flashes constantly it means that the programmed maintenance is required.

11. Reversibility.

The reverse command is encased within the screwdriver body to protect it from wear, collision or damage and accidental activation. A single press of the **button when the screwdriver is** not in action inverts the rotation (indicated by the blue LED). Holding the button for at least four seconds starts up the “SMART PRO” **programming mode** (indicated by the LED flashing).

12. Start up ergonomics.

The **start up lever** is another “**smart**” device in the system, designed to grant maximum freedom in terms of use. An analogic sensor with **exceedingly sturdy mechanics/electronics** that are **not susceptible to wear** mean it can be **contactless**. Pressed, it slots perfectly into the tool’s casing thus **ergonomically supporting to the user’s hand**. In addition, the **force** required to start a tool at the beginning of its cycle is **ergonomically irrelevant: work is less tiring thus productivity is at a maximum**.



Reliability.

A long-term project.

eTensil components are built to guarantee the highest levels of **reliability and safety** throughout the life cycle of any operation. The engineering involved in the mechanics, the cleanliness in the design and performance tests passed, all arise from **Fiam's wide Know-how of knowledge and specialist patents within the industrial tightening industry.**

13. Latest generation brushless motor.

Brushless motors are the avant-garde in efficient and consistent performance, due to their **high-precision mechanics**.

eTensil has been designed in order to obtain endless electric lifespan, thanks to the implementation of low wearing components, to low motor inertia and to a lower heating of the assembly. Hall sensors allow the user to **have full control of rotation** and ironless systems **make the motor so light**.

14. Reduction assembly.

Increased performance in output, **duration and noise level are the principles** that guide the latest designs in gear assembly - aims we have achieved through research focused on ensuring gear lifespan and efficiency as well as the careful sizing and the incorporation of treatment options into the manufacturing cycle. **Such innovative** ways of working mean the gear assembly remains practically **unchanged** even after **thousands of operational hours**, as our lab tests prove.

15. Modular structure.

Functionalities integrated into the circuit board, reduced and simplified electrical connections, its clean design, the modularity and the seamless integration of electronic components into the mechanics; all bases of the constructive **strength, designed to last and guarantee safe** and efficient servicing.

16. Connection cable screwdriver - control unit.

The cable is **extremely flexible**, with **sturdy connectors**, designed to last over time and made entirely in Italy upon Fiam's specifications. Standard length is 3 metres, which can be increased by adding additional cables. **Extremely resilient**, flame resistant and hallogen-free, designed to resist oils and to face extreme conditions of use in an industrial environment. The connection to the control unit is positioned at the back of the unit itself, allowing a better view to the display.



Ergonomic design. Perfection in handling.

eTensil design takes care of both **appearance and functionality**. Ergonomics has always been the central point of Fiam design and key strength in provided solutions. In perfect Italian style, the design also adheres to the combination of form and matter, with linearity and refined layout.

17. Ergonomic grip.

The grip has been designed and manufactured with the clear goal to reduce any fatigue and optimize productivity. Materials, horizontal grip-shaping, and the casing layout provide a stable rest point for the hand. All such details reveal a research for functionality and aesthetics. The grip is made of **innovative materials** ensuring a better resistance against any form of collision or damage. It is placed close to the tightening area, making the centring easy and fast. Easy to handle, **combining low** weight and dimensions. Suitable for both left and righthanded users, as **well** as for the **smaller and female hands**.

18. Reduced-effort start up.

The **pressure required to activate** lever start up is **much lower** than others available on **the market**. **Reducing the effort** the user needs to sustain over the course of the working day, will result in increase of production efficiency.

19. Several models for different needs.

Angle screwdrivers are ideal solutions where tightening has to be done in tight and hard-to-reach areas. **Their 30° or 90° heads - which are extremely compact** to reach awkward tightening areas - have been **designed and manufactured with innovative materials** that make them **wear resistant** (and hence low maintenance), while delivering **impressive tightening precision**. Models available with start lever only. **Operating layouts change** and the tightening points are located on **vertical wall?** Straight screwdrivers can be converted to pistol screwdrivers, making the tightening job 100% ergonomically sound. The pistol grip - available on request - results in an extremely balanced new grip that is also suitable where hanging systems are not an option.

20. Noise level and comfort.

eTensil ergonomic design also ensures low noise and comfort. All of the screwdrivers' mechanical elements have been designed to be **noiseless** - motor, gears. The tool is equipped with quick change chuck: easy and safe to use, it allows the user to quickly change bits. The presence of a **suspension device** eliminates the need for the user to support the tools. All of these features are essential to eTensil's unparalleled ergonomics.



Safety. Green performance.

Fiam has always **considered as a priority the safety of the working tools**, which play a vital role in the assembly process. The eTensil project has grown into its current strategical importance over a long **certification process** that has involved collaboration between Fiam and three external laboratories in a series of “pre-compliance” tests. Fiam guarantees that its range of electric screwdrivers **fully complies with latest electrical safety, EMC and ESD directives**.

21. Low environmental impact.

No sliding electrical contact in the brushless electric motors prevents carbon and blade dust emissions thus creating a safer working environment. All eTensil components are made of **recyclable materials**, making it easy to dispose of them.

The entire system in every element of the eTensil screwdriver range has been designed with the Life Cycle Assessment in mind: from supply chain to finalisation, from production to product transport, from usage to disposal.

22. ESD certification.

Casing of eTensil range has been made using the latest technology in ESD dissipative plastic, **thus avoiding the build up of electrostatic charge**. Any electrical charges transferred by the user to the tool (and vice versa) are discharged to the ground **without intruding upon the tightening area**. In compliance with the latest European Directives, the eTensil range **is immune to electromagnetic disturbances** generated by cables or as a result of the interference of other devices. The tools do **not influence** other devices either. This is a huge advantage when **assembling high-quality electrical components** that must be protected from the build up of electrostatic charge.

23. “Dust proof” construction.

The casing of eTensil is designed and manufactured to reduce as much as possible dust and other waste or substances infiltrations, that can compromise functionality of the tool. The most exposed parts of the screwdrivers are **duly sealed**. This greatly reduces potential functioning issues linked to external, damaging factors. In addition, all labels are enclosed within the casing to keep them protected from wearing and ensure traceability.

24. Maximum safety.

Operating at low-voltage (32 volts) means **maximum safety**. Special ergonomic grips guarantee perfect **thermal isolation**.



Screwdrivers technical features.

	Type of screwdriver		Grip	Tightening torque on soft joint		Idle speed	Starting system	Reversibility	Weight	Dimensions mm	Power consumption	Accessories
	Model	Code	Type	Nm	in lb	r.p.m.	Type	Type	kg	L x Ø	Volt	Drive
STRAIGHT MODELS	E8CC2A-2000	111712100		0,3 ÷ 2	2.6 ÷ 17.7	300 ÷ 2000	*		0,76	275x39	32	⬡ F1/4"
	E8CC3A-1200	111712101		0,3 ÷ 3	2.6 ÷ 26.5	180 ÷ 1200	*		0,76	275x39	32	⬡ F1/4"
	E8CC4A-900	111712102		0,3 ÷ 4	2.6 ÷ 35.4	135 ÷ 900	*		0,76	275x39	32	⬡ F1/4"
	E8CC5A-650	111712103		0,3 ÷ 5	2.6 ÷ 44.2	100 ÷ 650	*		0,76	275x39	32	⬡ F1/4"
	E8CC7A-350	111712104		0,4 ÷ 7	3.5 ÷ 61.9	55 ÷ 350	*		0,76	275x39	32	⬡ F1/4"
30° ANGLE MODELS	E8CC2A30-2000	111712135		0.3 ÷ 2	2.6 ÷ 17.7	300 ÷ 2000	lever start		0,76	327x39	32	□ M1/4"
	E8CC3A30-1200	111712136		0.3 ÷ 3	2.6 ÷ 26.5	180 ÷ 1200	lever start		0,76	327x39	32	□ M1/4"
	E8CC4A30-900	111712137		0.3 ÷ 4	2.6 ÷ 35.4	135 ÷ 900	lever start		0,76	327x39	32	□ M1/4"
	E8CC5A30-650	111712138		0.3 ÷ 4,5	2.6 ÷ 39.8	100 ÷ 650	lever start		0,76	327x39	32	□ M1/4"
90° ANGLE MODELS	E8CC2A90-2000	111712130		0.3 ÷ 2	2.6 ÷ 17.7	300 ÷ 2000	lever start		0,76	327x39	32	□ M1/4"
	E8CC3A90-1200	111712131		0.3 ÷ 3	2.6 ÷ 26.5	180 ÷ 1200	lever start		0,76	327x39	32	□ M1/4"
	E8CC4A90-900	111712132		0.3 ÷ 4	2.6 ÷ 35.4	135 ÷ 900	lever start		0,76	327x39	32	□ M1/4"
	E8CC5A90-650	111712133		0.3 ÷ 4,5	2.6 ÷ 39.8	100 ÷ 650	lever start		0,76	327x39	32	□ M1/4"
	E8CC8A90-250	111712134		0,5 ÷ 8	4.4 ÷ 70.8	40 ÷ 250	lever start		0,93	334x39	32	□ M3/8"
	E8CC2A90-2000-BITS	111712140		0,3 ÷ 2	2.6 ÷ 17.7	300 ÷ 2000	lever start		0,76	327x39	32	⬡ F1/4" BITS
	E8CC3A90-1200-BITS	111712141		0,3 ÷ 3	2.6 ÷ 26.5	180 ÷ 1200	lever start		0,76	327x39	32	⬡ F1/4" BITS
	E8CC4A90-900-BITS	111712142		0,3 ÷ 4	2.6 ÷ 35.4	135 ÷ 900	lever start		0,76	327x39	32	⬡ F1/4" BITS
	E8CC5A90-650-BITS	111712143		0,3 ÷ 4,5	2.6 ÷ 39.8	100 ÷ 650	lever start		0,76	327x39	32	⬡ F1/4" BITS

Legend

E8C2A-2000 = Electric screwdriver with torque/angle current control system
E = Electric
8 = Power of motor in watt/10
C = Screwdriver
C = Torque/angle current control system

2 = Maximum tightening torque in Nm
A = Torque control with automatic shut off
90 = 90° angle model
30 = 30° angle model
2000 = Speed
BITS = Female hexagonal output coupling for inserting tools

All screwdrivers are supplied with a working speed equal to 25% of the nominal one to guarantee tightening quality and precision. In order to obtain the nominal torque and speed range, it is necessary to set parameters following the instructions given in Use and Maintenance Manual. For any further information, contact the Fiam Technical Service.

Legend

Reversibility: all models are suitable for tightening and untightening operation

* Starting system: 4 available modalities for all models

- Lever start
- Push to start
- Lever start + push to start
- Latched lever + push to start

The "latched lever" + push to start mode allows the screwdriver to work without need to keep the lever pressed. For safety, the screwdriver activates only when pushing on the bit. In this mode, the first pressure applied to the lever starts the screwdriver until clutch shuts off, whereas a second pressure can eventually stop it before the working cycle is completed.

• Accessory drive: female hexagonal drive 1/4", 6,35 mm (ISO 1173).

• The code number must be used when ordering.

Torque values refer to analysis of laboratory performing tests that comply with the standard ISO 5393 with screwdriver set at to the maximum speed and should be considered as indicative. The values in real applications can be influenced by many factors such as, for example: joint (type of joint, degree of elasticity), screw (type and length), accessory used (type or length of the blade), tightening speed, assembly conditions (free standing screwdriver, screwdriver mounted on a torque arm), operator behavior during the tightening phase. For any further details, please address to Fiam Technical Service.

Standard equipment (supplied with the tool)

- Connection cable to control unit (code 686903834); length 3 mt and with error proof connection system
- Hanging ring
- Eco-friendly packaging
- Use and maintenance manual.



eTensil screwdrivers, nutrunner motors and TPU control units, are covered by an extended warranty of 24 months or 1.000.000 cycles (first goal achieved).

Control unit technical features.

Model	Code	Speed	Nr. of connectable tools	Tool feed tension	Feed input	I/O	Visual indicators	Weight kg	L x Width x H mm
TPU-C1	686200105	Adjustable	1	32 VDC	230 Vac ±10% 50-60 Hz	8 inputs 8 outputs 9 + 11 signal types	7 LED DISPLAY	0,8	185x150x105
TPU-C3	686200107	Adjustable	1	32 VDC	230 Vac ±10% 50-60 Hz	8 inputs 8 outputs 21 + 22 signal types	7 LED DISPLAY	0,8	185x150x105
TPU-C1-120V	686200106	Adjustable	1	32 VDC	120 Vac ±10% 50-60 Hz	8 inputs 8 outputs 9 + 11 signal types	7 LED DISPLAY	0,8	185x150x105
TPU-C3-120V	686200108	Adjustable	1	32 VDC	120 Vac ±10% 50-60 Hz	8 inputs 8 outputs 21 + 22 signal types	7 LED DISPLAY	0,8	185x150x105

Standard equipment

- Control unit are fitted with cable and European plug (TPU-C1 and TPU-C3), American plug (TPU-C1-120V and TPU-C3-120V)
- Use and maintenance manual
- The unit is equipped with adjustable tilt foot
- Eco-friendly packaging

Accessories available upon request

- Fixing plate to position** the power supply unit on any surface. It is supplied complete with screws, and can be anchored vertically or on a horizontal support (code 692080000).



LED Indicator

3 colours bulb, to be connected to units through 1,5 mt long cable included in supply. It allows the immediate feedback of the tightening process status. It can be fixed to the workbench.

Model	For units	Code
LED Indicator	TPU-C1 TPU-C3	686990039



Tower-light with audible buzzer

3 colours tower-light, equipped with an audible buzzer to be connected to TPU C1/TPU C3 control units. through 3 mt long cable included in supply. It allows, with lights and sound signals, the immediate feedback of the tightening process status. Diameter of 55 mm, it can be fixed to the workbench.

Model	For units	Code
Tower-light with audible buzzer	TPU-C1 TPU-C3	686990040



SPS (Socket and Program Selector).

Poka Yoke device for selection of fastening program by picking up of sockets/bits, can work together with TPU C3 control unit. It allows the selection of up to 8 sockets or bits (with diameter up to 80 mm) and checks correspondence between socket and pre-set tightening program as indicated from linked controller. Selection LEDS and socket pick-up acoustic signal (buzz): each socket spot is indeed connected to a particular program in the controller so that, when the worker picks one socket the controller is automatically set in accordance.

Available for OPS-Open Program Selection or CPS-Controlled Program Selection.

For further information refer to the catalogue No. 97: *SPS - Socket Program Selector*.

Model	Code	Unit to use	Dimensions (hxpL) mm	Weight Kg
SPS for TPU C3	687010055	TPU C3	239x310x63	5,8

- For diameters higher than 42 mm, special socket tray:
until 64 mm code 687019016
until 80 mm code 687019022

Accessories.



Screw suction system.

For all eTensil straight screwdrivers and nutrunner motors.

Special head (2) to be attached to the tool using the Connection kit (3) and to be connected to the SSU - Vacuum pump. Attached to the head is a special nozzle (1) that can be customized to suit the screws in question or the part to be assembled, which should be submitted to Fiam as a sample. We will also assess the bits (4) to determine the best solution for the screw type.

Model	Code
Screw suction head*	682119050
Connection kit (for screw suction head and screwdriver)	681041036
Connection kit (for screw suction head and nutrunner motor)	681041038
Custom nozzle	upon request
Custom blades	upon request

* supplied with screw suction tube to be connected to the vacuum pump.

SSU - Vacuum pump

Designed and manufactured by Fiam. Necessary for the suction of the screws, it works at 220 Volt-50 Hz with a use of power of only 45 Watts. Supplied with power cable.

Model	L x Width x H mm	Code
SSU - Vacuum pump for screw suction system	210 x 150 x 140	676000120

PISTOL GRIP



AUXILIARY GRIP



Pistol grip

code 681041029

To convert straight models into pistol models.

Auxiliary grip

code 681041030

When using straight screwdrivers at torques higher than 4 Nm, it is good practice to use the auxiliary grip, which reduces the reaction by distributing it over two hands rather than one.



CONNECTION CABLE



Connection cable complete with 90 ° angled fitting

code 686903841

3m-long cable connecting the screwdriver and power supply.

It can be ordered separately and is useful when the screwdriver is transformed from straight to pistol and the power cable drops from above.

Connection cable

code 686903834

The 3m-long cable connecting the screwdriver and power supply unit comes with the screwdriver, though it can also be ordered separately and joined to the cable provided to achieve greater lengths. Please check with the Fiam Technical Advice Department for the maximum length that can be produced.



Multiple connector for I/O

code 692079193

To be connected to the 25-pole I / O ports of Fiam TPU units. It allows to make the I/O signals available on 3 connectors and therefore the connection with 3 devices in parallel. Equipped with connection cable between unit and multiple connector and relative power supply, it has 8 status LEDs for Outputs and 8 test buttons for Input signals.

Accessories.

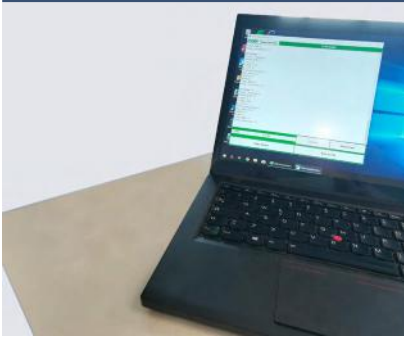

Kit Fiam HyperTerminal

code 686200913

Fiam HyperTerminal Kit **allows to connect all Personal Computers** (including those of the latest generation) **so the network systems**, with Fiam units equipped with an RS 232 serial port. For example, by connecting TPU control unit, it is possible to obtain the tightening results or download the configuration parameters of the set programs, thus allowing data storing to PC.

The kit includes:



USB key containing the HyperTerminal software

The exclusive software designed by Fiam with which it is possible:

- display on the PC text strings received via serial communication
- create both text files and CSV format files for Excel with the collected data
- save the data on the PC for the processing of statistics and analysis on production processes.



Adapter cable

RS232 to USB converter cable, to connect the Unit to the Personal Computer. To use this cable, it is necessary to install the relative Drivers contained in the USB key on the Personal Computer.



NULL Modem adapter

Optional adapter that can be used with other control units produced by Fiam such as shown in the table below.



Gender Changer Serial Adapter

Optional 9-pole "Female Female" type adapter that can be used with the other control units produced by Fiam as shown in the table below.



Serial cable

3 meters long with Male / Female connector to connect the unit directly to devices equipped with an RS 232 port or via the Adapter Cable.

Type of Fiam unit	Adapter cable RS232 to USB	NULL Modem adapter	Gender Changer Adapter
TPU-M1, TPU-C1 and TPU-C3 units	x		

Example screenshot of data coming from serial port

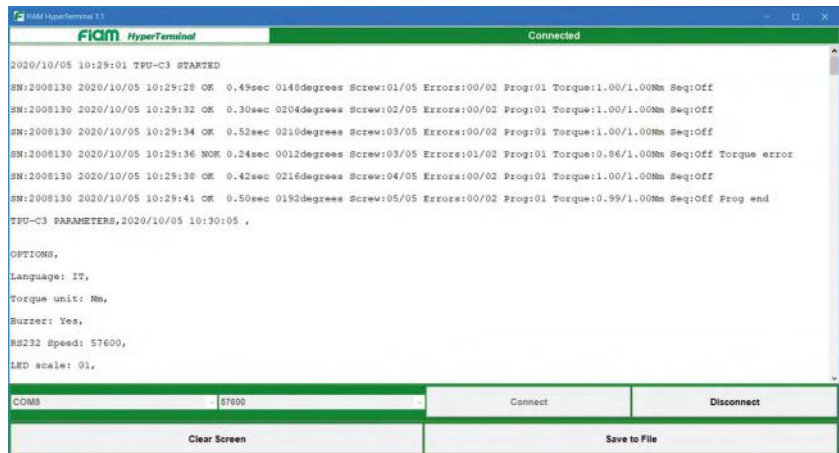

Continuous monitoring. Controlled production.

The eTensil range is available for integration with **production cycle monitoring systems**, such as TPM unit. Produced entirely by Fiam, these systems are equipped with a series of acoustic and visual alerts, allowing users to continuously monitor work processes, thus guiding them through the assembly stages. These systems eliminate post-process controls, they are easy to use and intuitive to set up.

25. TPM. Tightening *Position Monitor.*

TPM is an auxiliary system that increases the efficiency of tightening operation cycles by monitoring all the sequences concerned with tool positioning **at the tightening point**. This consists of a **telescopic magnesium arm** and a **TPM monitoring unit** that both guides users through the operations and ensures that the **final product is assembled in line with the required specifications**. The telescopic arms can be supplied with the TPM and come in two versions: one allows the device to perform **angular movement detection**, another **angular and linear movement detection**. Discover them on page 20.

Guided positioning.

The system locates the screwdriver's position in a tightening process and stores this in its memory. It also stores the sequence of actions and the number of screws used. Storing this information is part of the system's "self-learning" process.

How the system works.

The screwdriver activates when it finds the first position stored in its memory: POS-OK appears on the TPM display and the POS-OK LED on the telescopic arm lights up. For every screw tightened, the REMAIN display indicates how many screws are left to tighten, allowing the system to proceed to the next one. The END signal lights up once the memorised cycle is complete and permits users to proceed to a new working cycle.

TPM.



Up to 35 positions/screws per programme, up to 8 programmes.

When programming the sequence and positions, users can set a precision tolerance depending on the extension distance: e.g. $\pm 10\%$ for a length of approx. 1 mm; 0.1 degrees for an angle (maximum tolerance).

The large graphic display guides users step-by-step towards the tightening point. Once reached, all the green LEDs light up to signal

that the user may proceed with the tightening process; the small display instead shows the number of screws left to tighten.

Cartesian and telescopic arms.

These completely counteract the reaction on the operator's hand, the force required to support the tool and the vibrations to the hand-arm system. They make it possible to keep the wrist in a good position with the tool perpendicular to the work point, improving working accuracy and production process quality.



BT-MG magnesium telescopic arms

Telescopic arms in magnesium alloy, designed and produced by Fiam, extremely resistant to mechanical stress thus guaranteeing reliability and long life span, thanks to accurate manufacturing process and applied innovative materials.

Designed with different telescoping extension elements (3 for all models and 2 for BT-MG 10...), they are conform for working areas according to various productive needs. Double terminal coupling guarantees great handiness and maximum freedom of action also for inclined tightening operations. They can be easily installed using a simple plate with reduced dimensions.

Model	Code	Max torque		Max work range	Min work range	Ø max tool
		Nm	in lb	(mm)	(mm)	(mm)
BT-MG 10 800	692071420	10	88.50	650	470	26.5-50
BT-MG 10 1000	692071421	10	88.50	790	540	26.5-50
BT-MG 15 800	692071409	15	132.70	860	505	26.5-50
BT-MG 15 1000	692071401	15	132.70	1070	575	26.5-50
BT-MG 15 1500	692071404	15	132.70	1580	745	26.5-50

Tool holder accessory (1)

code 692079180

Only for eTensil straight models. To install the screwdriver on BT-MG reaction arm. It allows 9 rotation positions of the screwdriver on its own axis.



BCA Articulated cartesian arm

BC and BCA Cartesian arms

Cartesian arms fundamental solutions for ergonomics workplace, designed and manufactured by Fiam, can be used with any type of tool with a diameter up to 50 mm and weight up to 11 kg.

• Cartesian arms

• Articulated cartesian arms

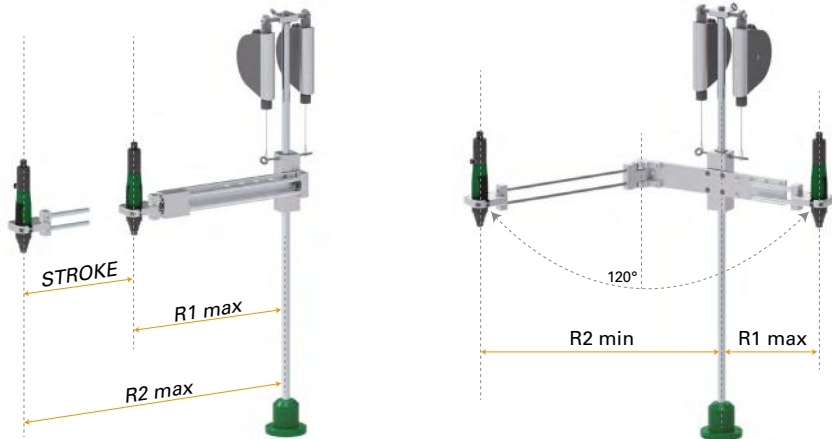

BCA-TOP Articulated cartesian arm

Model	Code	Max torque		Max work range R1	Min work range R2
		(Nm)	(in lb)	(mm)	(mm)
BC5 Cartesian arm	692031030	5	44,2	285-445	600-760
BC12 Cartesian arm	692031031	12	106,8	285-445	600-760
BCA5 Articulated cartesian arm	692031034	5	44,2	110-260	610-730
BCA12 Articulated cartesian arm	692031035	12	106,8	110-260	610-730
BC5-TOP Articulated cartesian arm	692031065	5	44,2	285-445	600-760
BC12-TOP Articulated cartesian arm	692031076	12	106,8	285-445	600-760
BCA5-TOP Articulated cartesian arm	692031067	5	44,2	110-260	610-730
BCA12-TOP Articulated cartesian arm	692031068	12	106,8	110-260	610-730

Tool holder accessories

code 692039108 (2)

For anchoring the straight screwdrivers to the Cartesian arm without damaging it or compromising its operation. Complete with assembly screws.

This accessory cannot be used with RE version eTensil screwdrivers (with external clutch adjustment).

code 681041034 (3)

An accessory for anchoring the top of the straight screwdriver to the Cartesian arm for a better view of the tightening point. Complete with assembly screws.

code 692039233 (4)

Universal clamp suitable to work on vertical or inclined surfaces using tools with pistol grip or angled heads. It promotes a good hand-arm system position by rotating around two axes. It cannot be used with BC25PK/BC40LK arms (see pagg. 23 and 35). For the best installation it can be combined with the accessory cod. 692039108 (ref. 2). Complete with assembly screws.

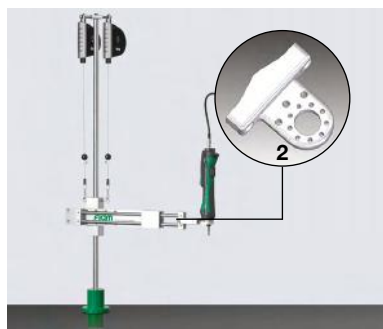

Several accessories to aid operation with the best ergonomics are availables (see [Accessories Catalogue no. 79](#)).

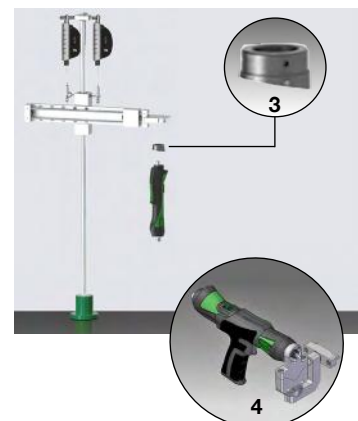



Arms with position monitoring device

All Fiam arms can be fitted with a **position monitoring device** and, **combined with the TPM monitoring unit**, help make tightening systems very suitable for "Poka-Yoke" processes, while increasing the efficiency and speed of the production cycle

There are two types:

- Arms with TPM-1: models with **single angle** movement detection
- Arms with TPM-2: models with **angle and linear** movement detection.

The arms must be integrated with the TPM monitoring unit code 692078019.

The guided positioning system operates as follows:

- It works through "self-learning": it locates the screwdriver position at the various tightening points and stores them together with the sequence of actions and the number of screws (up to 35 positions/program and up to 8 programs).
- The TPM unit display offers a graphical system to guide operators progressively as they approach the tightening point.
- The screwdriver is enabled when it is at the first stored position (the TPM display shows POS-OK and the POS-OK LED on the telescopic arm lights).
- Each time a screw is tightened, the REMAIN display shows how many screws are left, indicating that it is ready to pass on to the next screw.
- The END signal comes on when the stored cycle is complete, and gives the OK to proceed with a new work cycle.
- During the memorization process, a precision tolerance can be programmed within the range: for example, for a length of 1 mm \pm 10% approximately; for the angle 0.1 degrees (maximum tolerances).

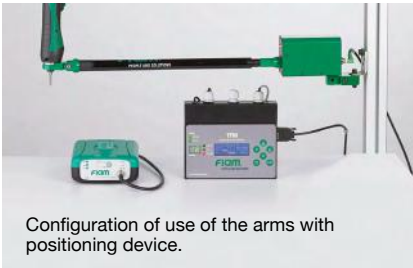

Configuration of use of the arms with positioning device.



Cartesian arm with a position monitoring device.

Model	Code	Max torque Nm	Max torque in lb	Max work range (mm)	Min work range (mm)
Models with SINGLE ANGLE movement detection					
BT-MG 15 800 - TPM1	692071425	15	132,70	985	630
BT-MG 15 1000 - TPM1	692071426	15	132,70	1195	700
BT-MG 15 1500 - TPM1	692071427	15	132,70	1705	870
BC5 -TPM1	692031046	5	44,20	285-445	600-760
BC12-TPM1	692031047	12	106,80	285-445	600-760
Models with ANGLE and LINEAR movement detection					
BT-MG 15 800 - TPM2	692071422	15	132,70	985	630
BT-MG 15 1000 - TPM2	692071412	15	132,70	1195	700
BT-MG 15 1500 - TPM2	692071415	15	132,70	1705	870
BC5 -TPM2	692031042	5	44,20	285-445	600-760
BCA5 -TPM2	692031050	5	44,20	110-260	610-730
BCA12-TPM2	692031051	12	106,80	110-260	610-730

The BCA Cartesian arms are arranged only with the TPM2 device being configured to monitoring the angular and linear positions.



TPM - Tightening Position Monitor

Tightening position monitoring unit, to be used in combination with the selected arm, along with the TPU-C1 o TPU-C3 or TPU-C3 control unit and connection cable (code 692079192).

Length accuracy (mm): 1 \pm 10%

Angle accuracy (degrees): 0,1°

Maximum number of screws per program: 35

Number of programs: 8

Total number of screws: 280 (35 per program, 8 programs).

Model	Code	Dimensions (mm)	Electric feed
TPM - Monitoring Unit	692078019	208 x 128 x 42	24 V, 110/230V - 50/60 Hz

In case of use with CA autofeed screwdrivers, where TPU unit I/O port is used for connection to the screw feeder, to have connection with TPM, the Multiple connector for I/O is required. Code 692076193. See page 18.



Cartesian Arm BC25PK with Automatic downward pushing device.

An extraordinary aid to operators **who can take advantage of its automatic down pressure and hence perform tightening without having to apply pressure themselves. Pneumatic down pressure** can be set to suit the type of screw used by means of the practical control, which has an indicator showing working pressure.

While returning up after tightening, the arm **automatically returns to the rest position.**

Model	Code	Max torque Nm	Max torque in lb	Max charge (kg)	Push (kg)
BC25PK	692031054	25	221	4	3 ÷ 9

Suitable only for models with lever starting mode (straight and external clutch adjustment screwdrivers).

Tightening automation. Innovating production.

The eTensil series nutrunner motors. Innovation in automatic production processes draws on over 70 years' specialist knowledge of the ins and outs of the industrial tightening process in its every form. A solid, exclusive foundation on which Fiam has built the new eTensil electric nutrunner motors.

In addition to the **eTensil** motors, we also **design and manufacture all our industrial automation components entirely in-house**. The embodiment of our strict design standards and manufacturing excellence.

Electric solutions for taking the efficiency of tightening process automation to the next level: eTensil was devised as a proudly Italian response to the industry 4.0 demand for green work tools, offering high levels of performance and reliability, smart tools designed **to fit seamlessly into any smart manufacturing operation**.

1. Torque/angle current control system.

This technology offers the possibility of **adjusting the torque during operation**. This can be done simply by changing the specific parameter on the control unit, which is the "smart core" of this range of solutions.

2. On board electronics.

In this system **the torque is detected by measuring the current used by the motor. The angle is detected through specific hall sensors.**

3. Latest generation brushless motor

FIAM has designed and created an **innovative on board electronics**. As a result the system is easier to use, workplace layout is tidier, and data exchange between the nutrunner motor and the power unit is faster.

Brushless motors are the avant-garde in efficient and consistent performance, due to their **high-precision mechanics**. eTensil has been designed in order to obtain endless electric lifespan, thanks to the implementation of low wearing components, to low motor inertia and to a lower heating of the assembly. Hall sensors allow the user to **have full control of rotation** and ironless systems **make the motor so light**.

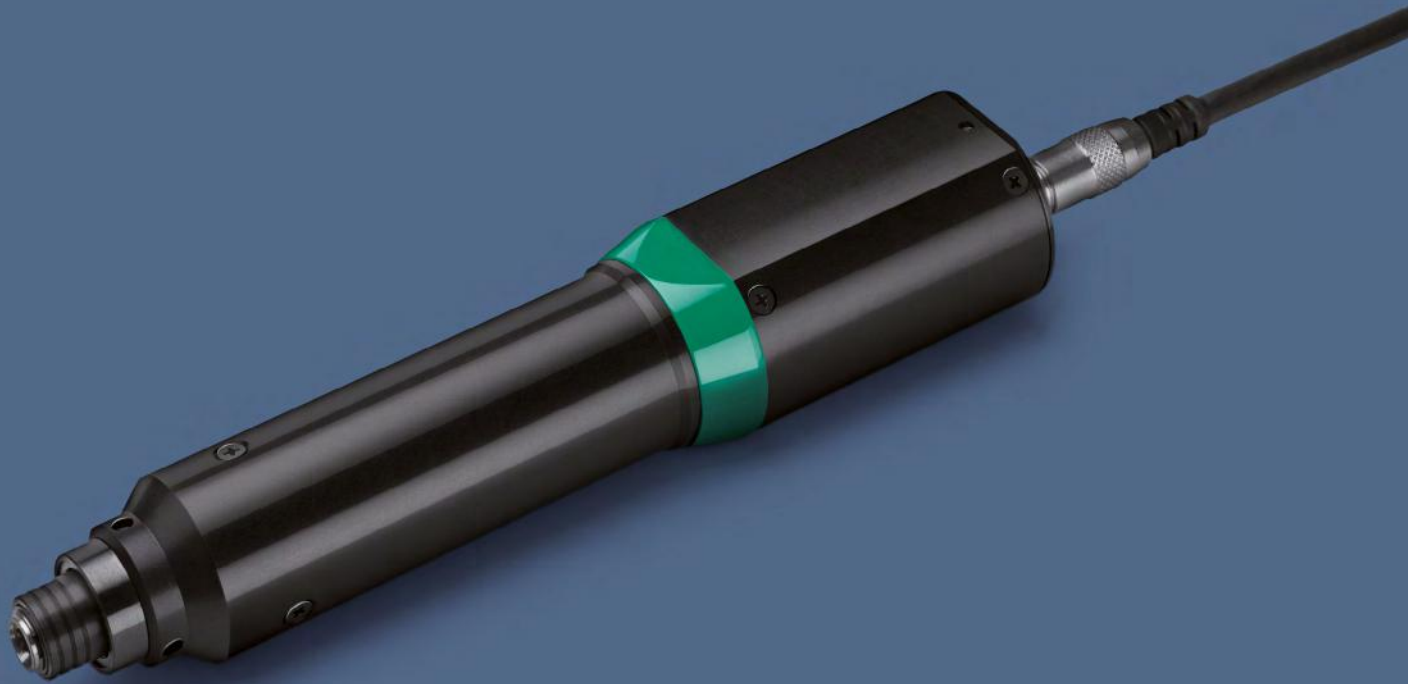

4. Reduction assembly.

Increased performance in output, **duration and noise level are the principles** that guide the latest designs in gear assembly - aims we have achieved through research focused on ensuring gear lifespan and efficiency as well as the careful sizing and the incorporation of treatment options into the manufacturing cycle. **Such innovative** ways of working mean the gear assembly remains practically **unchanged** even after **thousands of operational hours**, as our lab tests prove.

5. Modular structure.

Functionalities integrated into the circuit board, reduced and simplified electrical connections, its clean design, the modularity and the seamless integration of electronic components into the mechanics; all bases of the constructive **strength, designed to last and guarantee safe** and efficient servicing.

6. Connection cable nutrunner motor - control unit.

The cable is **extremely flexible**, with **sturdy connectors**, designed to last over time and made entirely in Italy upon Fiam's specifications. Standard length is 3 metres, which can be increased by adding additional cables. **Extremely resilient**, flame resistant and hallogen-free, designed to resist oils and to face extreme conditions of use in an industrial environment.

7. Construction you can rely on.

eTensil electric nutrunner motors are not just regular screwdrivers adapted to be installed on a machine: instead, they are **solutions specifically designed to be used in the industrial automation areas**. **They have features** that make them ideal for automation:

- **strong thrust bearings:** to withstand the thrust of the sort of slides found in automated production cycles that move in rapid, non-stop strokes
- **ideal external geometries:** to make machine mounting practical along the full length of the aluminium outer body
- **centring system** designed to achieve unbeatable reliability along both the vertical and horizontal axis.

Automatic screwdrivers. Productivity is within your reach.

The eTensil nutrunner motors have been designed for use also on manually operated automatic tightening systems too. Essential **when tackling tightening jobs with medium and large runs of identical screws**, they are great for speeding up the production cycle with their continuous supply of **screws that are automatically sent to the tightening point**. **Using systems like these, which interconnect with management systems of smart factories (INDUSTRY 4.0), does away with the manual stages** of picking up the screw and positioning it on the bit or on the part, with a 30%-plus reduction in cycle times. Available in various versions, providing the best possible solution for each production scenario.

8. EasyDriver screw feeders.

They manage the entire working cycle with great flexibility because they manage the tightening sequences quickly and easily, customizing them to the specific applications. They are all equipped with:

- **Integrated PLC** to manage all machine parameters
- **Modbus TCP/IP** protocol
- EDML software, **Webserver interface** for remote connection to tightening system.

More models available:

- to feed large screws
- to manage high production rates and have greater working autonomy
- models with dual circular bowls to process **2 geometrically similar** screws, for example differing in length or made from different materials
- with soundproofing devices.

9. Auto-advance device.

The eTensil nutrunner motor can be used in conjunction with the auto-advance device designed and manufactured by Fiam that allows the **bit to advance automatically** during the tightening stage, thus reducing operator fatigue, at the same time ensuring the screw is visible at all times and not allowing the bit to pull back. In addition, the screwdriver's head does not rest on the surfaces, protecting them from any potentially damaging contact.

The **forward bit stroke** device is recommended for **effortless tightening** even thanks to the thrust of over 25 kg exerted by the blade that ensures reliable tightening on any type of joint and allows to work without the bit moving backs, even for example in the case of self-drilling screws. Tightening strokes can be chosen within the wide range of 100 mm and allow you to tighten in very **right spaces, up against walls or inside small or very deep holes**.

10. Telescopic device.

The **telescopic device** allows you to reach tightening points up against walls, in awkward spaces or inside holes. The various telescopic stroke options are: 40, 60 and 100 mm. The device's mechanics, as well as offering great smoothness of telescopic shaft, is equipped with a double sensor:

- **rest sensor:** always active, monitoring the head's stroke, it does not allow the screw to be called while tightening is still in progress. This benefits productivity as it stops screws jamming. The cycle stops when the set tightening torque is reached.
- **depth control sensor:** by measuring the tightening stroke, it allows the cycle to be stopped once screw height reaches the preset height.

11. Tightening heads.

The screw-retaining heads used mechanically hold the screw from the feeder and guide it correctly and safely to allow the bit to descend to the screw and tighten it onto the component.

Since they are essential for reliable tightening, they are full customized by Fiam, based on the know-how gained over the years.

Their benefits:

- **excellent screw holding**
- **perfect screw driving at the tightening point**
- **thanks to customized design, heads can process various screws sizes, even in embedded spots**
- **quick and easy assembly and disassembly.**

For further information refer to the catalogue No. 89: [CA-automatic screw feeding system](#).



MCA tightening modules.

They can be integrated anywhere.

MCA tightening modules with eTensil nutrunner motors are packed with innovation ready to make any production process even faster and more reliable. Solutions that are ready and tested for **integration into existent production lay out and which relate to the management systems of production plant (Industry 4.0) and can be managed remotely to increase reliability**, as well the quality of the tightening process and therefore of the end product.

12. All the benefits of MCA modules.

MCA modules comprise:

- eTensil nutrunner motors
- fastening slide
- screw-retaining head
- screw feeder.

With MCA modules:

- **screws are sent continuously and quickly** from the bowl feeder to the screw-retaining device
- the **approach** and subsequent **tightening** of the screw on the component is **automatic** and accurate
- the whole tightening cycle is **controlled and monitored by an integrated PLC** that interfaces with the automated production systems (Industry 4.0)

- the **resulting tightening cycles are complete** and autonomous, with a simple external start
- the fastening slides ensure a **precise approach stroke of the nutrunner motor/screw-retaining head to the component**, and are ideal to working even from the **bottom to the top and/or for layouts with reduced encumbrements**.
Light and compact they can also withstand substantial axial thrust (e.g. assembly with self-drilling screws) and can be supplied with “Screw at sight” function to facilitate screw engagement movement before steps of approach and subsequent tightening

- the EasyDriver screw feeders **manage the entire working cycle** with great flexibility: they control the tightening sequences quickly and easily, customizing them to the specific applications. They are all equipped with
 - **Integrated PLC** to manage all machine parameters
 - **Modbus TCP/IP** protocol
 - EDMI software, **Webserver interface** for remote connection to tightening system
 - Many sensors and devices designed to eliminate any possible downtime.

13. Versatile anywhere.

Ideal for:

- assembly lines
- turntables
- manipulators
- cartesian axes x,y,z: in order to tighten at different working heights
- robots
- cobots.

For further information refer to the catalogue No. 73: [MCA-Tightening module to be integrated into automatic production systems](#).



Fiam

PEOPLE AND SOLUTIONS

EasyDriver

www.fiamgroup.com

Fiam

PEOPLE AND SOLUTIONS

www.fiamgroup.com

Tighten with Cobots.

Humans take a leading role.

There will be a **growing use** of “smart machines”, or **collaborative robots**, in production systems. These solutions are not destined to replace humans, but to collaborate with them and **free them from the heavier and more dangerous tasks, allowing them to provide the real added value in their work**. Operators, or humans, become the ideal means for carrying out complex operations, and their **skills are extended** through a process of “*job enlargement*”, in which they are asked to **perform the more critical tasks** so that their daily work is more motivating and their jobs are more highly qualified.

14. The MCA module for Cobots.

These tightening modules pair perfectly with all collaborative robots on the market.

There is a growing use of smaller cobots on assembly lines as they are ideal for:

- **automating repetitive operations and making the best use of the operators' skills**
- **carrying out most tightening jobs automatically**
- **being quickly reprogrammed and used for different applications.**

Ease of programming and very fast setup.

15. Smart feeders.

In addition to relating to the line PLC and the control unit of the nutrunner motor, the available screw feeders are equipped with **Modbus TCP/IP communication** protocol, that enables broader and faster communication - via Ethernet connection - of all work-cycle-related information and digital Input and Output signals exchanged with and sent to the Cobot. It enables the Cobot to change the feeder's operating parameters. Moreover, specific sensors check whether the screw has dropped into the hose properly and ready it for subsequent shooting: this avoids screws jamming and building up in the screw shooting hose and ensures uninterrupted work.

16. Auto-advance device.

Designed to be fixed to the cobot's wrist, this device **allows the bit to advance to the tightening point automatically** and not allows it to withdraw. During the tightening stage, the screwdriver's head does not rest on the surfaces, protecting them from any potentially damaging contact. The device houses an eTensil nutrunner motor.

17. Safe.

Since the auto-advance device requires hardly any thrust for tightening, this system is **perfectly in line with safety requirements**. In addition, the screw is **always held inside jaws** and it is only shot out once the **screwdriver head is positioned by the cobot over the tightening point**: this means that the tip of the screw is never exposed during handling and hence cannot hit the operator.

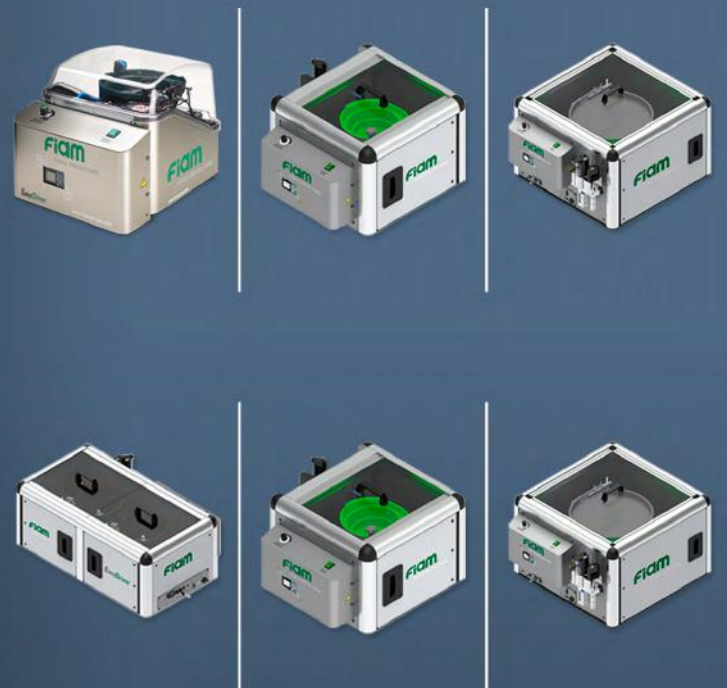
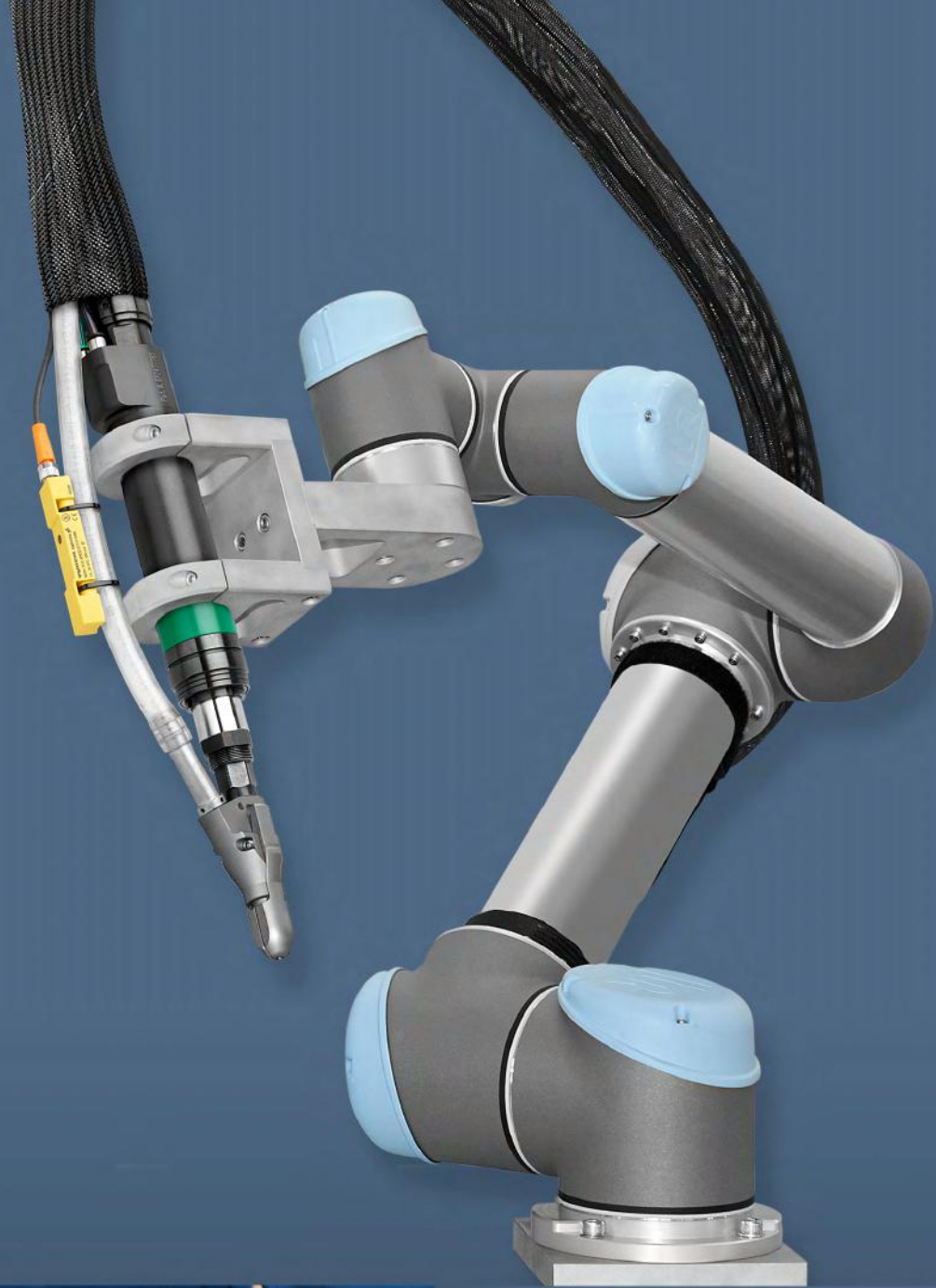

Nutrunner motors technical features.

Type of nutrunner motor	Code	Tightening torque on soft joint		Idle speed Min. / Max.	Reversibility	Weight	Accessories	Dimensions L x Ø
		Min. / Max.						
Model	Code	Nm	in lb	r.p.m.	Type	kg	Drive	mm
E8MCC2A-2000	111712710	0,3 ÷ 2	2.6 ÷ 17.7	300 ÷ 2000		0,68	⬡ F1/4"	233x36
E8MCC3A-1200	111712711	0,3 ÷ 3	2.6 ÷ 26.5	180 ÷ 1200		0,68	⬡ F1/4"	233x36
E8MCC4A-900	111712712	0,3 ÷ 4	2.6 ÷ 35.4	135 ÷ 900		0,68	⬡ F1/4"	233x36
E8MCC5A-650	111712713	0,3 ÷ 5	2.6 ÷ 44.2	100 ÷ 650		0,68	⬡ F1/4"	233x36
E8MCC7A-350	111712714	0,4 ÷ 7	3.5 ÷ 61.9	55 ÷ 350		0,68	⬡ F1/4"	233x36

Legend

E8MCC3A-2000 = Electric nutrunner motor with torque/angle current control system
E = Electric

8 = Power of motor in watt/10
MC = Nutrunner motor
C = Torque/angle current control system

3 = Maximum tightening torque in Nm
A = Torque control with automatic shut off
2000 = Speed

All nutrunner motors are supplied with a working speed equal to 25% of the nominal one to guarantee tightening quality and precision. In order to obtain the nominal torque and speed range, it is necessary to set parameters following the instructions given in Use and Maintenance Manual. For any further information, contact the Fiam Technical Service.

Legend

Reversibility: all models are suitable for tightening and untightening operation

Starting system

Remote start

- Accessory drive: female hexagonal drive 1/4", 6,35 mm (ISO 1173).
- The code number must be used when ordering.

Torque values refer to analysis of laboratory performing tests that comply with the standard ISO 5393 with screwdriver set at to the maximum speed and should be considered as indicative. The values in real applications can be influenced by many factors such as, for example: joint (type of joint, degree of elasticity), screw (type and length), accessory used (type or length of the blade), tightening speed, assembly conditions (free standing screwdriver, screwdriver mounted on a torque arm), operator behavior during the tightening phase. For any further details, please address to Fiam Technical Service.

Standard equipment (supplied with the nutrunner motor)

- Connection cable to control unit (code 686903834); length 3 mt and with error proof connection system
- Eco-friendly packaging
- Use and maintenance manual

Models and accessories available upon request

- Motors with axial compensator 1/4" drive (code 680601090), 3/8" drive (code 680601070), 1/4" quick change chuck (code 680601080)
- Motors with off-set device (for narrow distances between the axis) - code 680601185
- Motors with off-set device with axial compensator - code 680601190
- To use the offset device, you must order the adapter - code 687029248
- Fixing flange 36 mm in diameter - code 684011007
- Motors with modified flange and / or with customized body design
- Motors with angled head

N.B.: The offset device can be used with motors up to 5 Nm.

Control unit technical features.

Model	Code	Speed	Nr. of connectable tools	Tool feed tension	Feed input	I/O	Visual indicators	Weight kg	L x Width x H mm
TPU-C1	686200105	Adjustable	1	32 VDC	230 Vac ±10% 50-60 Hz	8 inputs 8 outputs 9 + 11 signal types	7 LED DISPLAY	0,8	185x150x105
TPU-C3	686200107	Adjustable	1	32 VDC	230 Vac ±10% 50-60 Hz	8 inputs 8 outputs 21 + 22 signal types	7 LED DISPLAY	0,8	185x150x105
TPU-C1-120V	686200106	Adjustable	1	32 VDC	120 Vac ±10% 50-60 Hz	8 inputs 8 outputs 9 + 11 signal types	7 LED DISPLAY	0,8	185x150x105
TPU-C3-120V	686200108	Adjustable	1	32 VDC	120 Vac ±10% 50-60 Hz	8 inputs 8 outputs 21 + 22 signal types	7 LED DISPLAY	0,8	185x150x105

Standard equipment

- Control unit are fitted with cable and European plug (TPU-C1 and TPU-C3), American plug (TPU-C1-120V and TPU-C3-120V)
- Use and maintenance manual
- Eco-friendly packaging
- The unit is equipped with adjustable tilt foot

Accessories available upon request

- **Fixing plate to position** the power supply unit on any surface. It is supplied complete with screws, and can be anchored vertically or on a horizontal support (code 692080000)
- **Signal lights and various accessories for control unit:** see p. 17
- **Fiam HyperTerminal** kit to manage tightening results: see p. 19.



eTensil screwdrivers, nutrunner motors and TPU control units, are covered by an extended warranty of 24 months or 1.000.000 cycles (first goal achieved).

Dimensions.

Electric nutrunner motor.

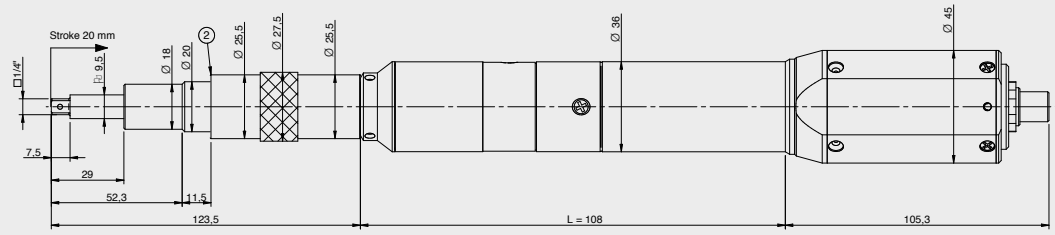

Square drive axial compensator □ 1/4" (Din 3121-F 6,3) - code 680601090

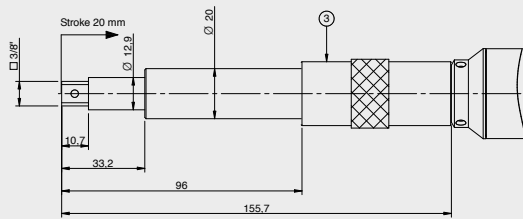

Square drive axial compensator
□ 3/8" (Din 3121-F 10) - code 680601070

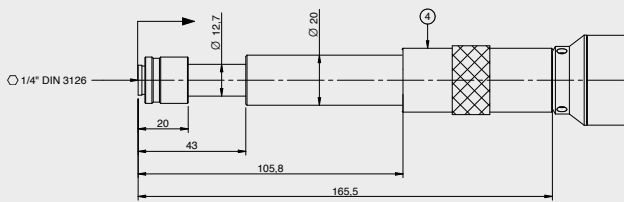

Axial compensator with 1/4" hex. □ quick change
chuck (Din 3126-F 6,3) - code 680601080

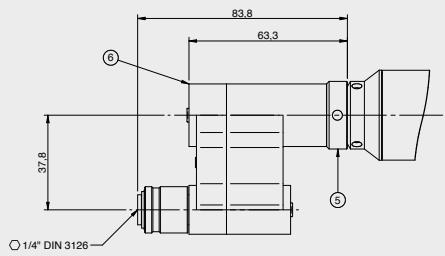

Offset device for very
small centre-to-centre
distances
code 680601185

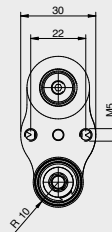
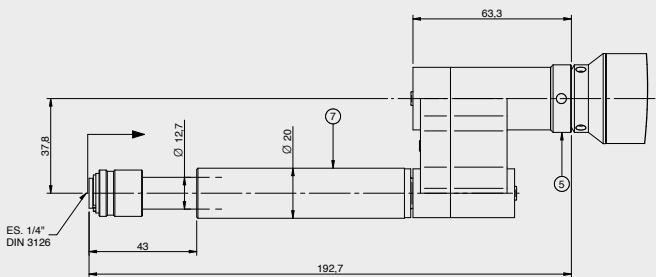

Offset device with
axial compensator
code 680601190

CA handheld tightening system: auto feed screwdrivers technical features.

Type of screwdriver	Grip	Tightening torque of eTensil screwdriver Min. / Max.		Idle speed Min. / Max.	Starting system	Reversibility	Control unit	EasyDriver screw feeder	
Model	Type	Nm	in lb	r.p.m.	Type	Type	Type	Type	
AUTO-ADVANCE DEVICE	CA E8MCC D AA C1/C3...		0,3 ÷ 7	2.6 ÷ 61.9	55 ÷ 2000	Lever start		TPU-C1 TPU-C3	ED B ED B 1 1 ED B M 1 1 ED B 2 1
	CA E8MCC PA AA C1/C3...		0,3 ÷ 7	2.6 ÷ 61.9	55 ÷ 2000	Push-button start		TPU-C1 TPU-C3	ED B ED B 1 1 ED B M 1 1 ED B 2 1
TELESCOPIC DEVICE	CA E8MCC D TE C1/C3...		0,3 ÷ 7	2.6 ÷ 61.9	55 ÷ 2000	Push to start		TPU-C1 TPU-C3	ED B ED B 1 1 ED B M 1 1 ED B 2 1
	CA E8MCC PA TE C1/C3...		0,3 ÷ 7	2.6 ÷ 61.9	55 ÷ 2000	Push to start		TPU-C1 TPU-C3	ED B ED B 1 1 ED B M 1 1 ED B 2 1

Legend	
	Non-reversible screwdriver (only tightening) The telescopic model provides also tightening on screws with left thread.
Tightening system	CA
Type of screwdriver	E8MCC Electric technology eTensil
Type of grip	D Straight P Pistol PA Forward pistol
Tightening device	AA Forward bit stroke device TE Telescopic device
Type of control units	C1 = TPU-C1 - Control unit eTensil C3 = TPU-C3 - Control unit eTensil
Type of screw feeder	B = Easy Driver ED B B11 = Easy Driver ED B 1 1 BM11 = Easy Driver ED B M 1 1 B21 = Easy Driver ED B 2 1

Starting system	
	Lever start
	Push-button start
	Push to start

* Accessory drive: female hexagonal drive 1/4", 6,35 mm (ISO 1173).

Torque values refer to analysis of laboratory performing tests that comply with the standard ISO 5393 with screwdriver set at to the maximum speed and should be considered as indicative. The values in real applications can be influenced by many factors such as, for example: joint (type of joint, degree of elasticity), screw (type and length), accessory used (type or length of the blade), tightening speed, assembly conditions (free standing screwdriver, screwdriver mounted on a torque arm), operator behavior during the tightening phase. For any further details, please address to Fiam Technical Service.

All screwdrivers are supplied with a working speed equal to 25% of the nominal one to guarantee tightening quality and precision. In order to obtain the nominal torque and speed range, it is necessary to set parameters following the instructions given in Use and Maintenance Manual. For any further information, contact the Fiam Technical Service.

Standard equipment (supplied with CA handheld tightening system)

- Electric auto feed screwdriver
- EasyDriver feeder chosen
- TPU-C1 or TPU-C3 control unit
- Connection cables
- Ethernet connection cable
- Screw-retaining head customized for the screw, completed with bush
- 4 tightening bits (1 fitted + 3 spares)
- Extension for spare blade
- Screw shooting hose
- Shielded screw transit sensor (only for screwdrivers with forward bit stroke device)
- Hanging ring
- Operation and maintenance manual
- Eco-friendly packaging, dimensions mm: L 600 x 450 x h 520

Control unit technical features.

Model	Code	Speed	Nr. of connectable tools	Tool feed tension	Feed input	I/O	Visual indicators	Weight kg	L x Width x H mm
TPU-C1	686200105	Adjustable	1	32 VDC	230 Vac ±10% 50-60 Hz	8 inputs 8 outputs 9 + 11 signal types	7 LED DISPLAY	0,8	185x150x105
TPU-C3	686200107	Adjustable	1	32 VDC	230 Vac ±10% 50-60 Hz	8 inputs 8 outputs 21 + 22 signal types	7 LED DISPLAY	0,8	185x150x105
TPU-C1-120V	686200106	Adjustable	1	32 VDC	120 Vac ±10% 50-60 Hz	8 inputs 8 outputs 9 + 11 signal types	7 LED DISPLAY	0,8	185x150x105
TPU-C3-120V	686200108	Adjustable	1	32 VDC	120 Vac ±10% 50-60 Hz	8 inputs 8 outputs 21 + 22 signal types	7 LED DISPLAY	0,8	185x150x105

Standard equipment

- Control unit are fitted with cable and European plug (TPU-C1 and TPU-C3), American plug (TPU-C1-120V and TPU-C3-120V)
- Use and maintenance manual
- The unit is equipped with adjustable tilt foot
- Eco-friendly packaging

Accessories available upon request

- **Fixing plate to position** the power supply unit on any surface. It is supplied complete with screws, and can be anchored vertically or on a horizontal support (code 692080000)
- **Signal lights and various accessories for control unit:** see page 17
- **Fiam HyperTerminal** kit to manage tightening results: see p. 18
- **Multiple connector for I/O**, code 692076193. With CA autofeed screwdrivers, where TPU unit I/O port is used for connection to the screw feeder, to have additional connection, e.g. with TPM to have program selection, the Multiple connector for I/O is required. See page 19.



eTensil screwdrivers, nutrunner motors and TPU control units, are covered by an extended warranty of 24 months or 1.000.000 cycles (first goal achieved).



EasyDriver screw feeders for autofeed screwdrivers.

Feeders that can be used with CA auto feed screwdrivers are of different types:

EasyDriver ED B (1 x 240mm Ø bowl feeds 1 screwdriver)

Feeds the screws optimally and without jamming. For screws between 10 and 35 mm in length.

EasyDriver ED B 1|1 (1 x 240mm Ø bowl feeds 1 screwdriver).

Feeds the screws optimally and without jamming and used when greater soundproofing is required. For screws between 10 and 35 mm in length.

EasyDriver ED B MAXI 1|1 (MAXI 1|1 = 420mm Ø bowl feeds 1 screwdriver).

Used when the job involves large screws and also in the event of high production rates to allow the system to run unaided for longer. For screws between 35 and 60 mm in length.

EasyDriver ED B 2|1 (2|1 = 2 240mm Ø bowls feed 1 screwdriver).

With its dual circular bowls, it can process 2 geometrically similar screws, for example differing in length or made from different materials (e.g. stainless steel / browned steel) to feed a slide (one way). Screw choice is managed by a dedicated input. For screws between 10 and 35 mm in length.

For more information about the features refer to the catalogue No. 89:

[CA - Handheld tightening system with automatic screw feeding.](#)



Screw-retaining heads (nose piece).

They are completely customized to the customer's needs. Available with:

- **With anti-overturning device** for screws with length/head diameter ratio between 1.1 (approx.) and 1.5. To prevent screw jamming
- **With friction jaws** holding the screw on the head and not on the stem: jaws do not open, allowing screw insertion into holes
- **For big screws** to tighten screws up to 45 mm length
- **With hose** to reach embedded tightening points or inside holes
- **With support or protective spacer/special materials** to ease the positioning on the components and to avoid damaging them during assembly
- **With elastic hose and mechanical screw gripping.** Ensures the screw is held perfectly every time.

For more information about the features refer to the catalogue No. 89:

[CA - Handheld tightening system with automatic screw feeding.](#)



BC40LK cartesian arm.

Also with pneumatic locking device.

The BC40 and BCA40 Cartesian arms can be used with auto-feeding screwdrivers. The BC40LK model is specifically for use with auto-feeding screwdrivers with auto-advance, which provide an automatic pushing force on the workpiece to aid operators so that they do not have to apply force while tightening.

With this Cartesian arm, in addition to all the benefits offered by Fiam Cartesian arms (see page 24), operators can also profit from a **special device that counteracts the "recoil" caused by the tool bit during tightening** and redirects this force to the mechanical arm rather than that of the operator. When there is no power supply, the system stops automatically to prevent the pneumatic device from slipping and avoid any risk of crushing and/or accidental movement.

It can also be used in conjunction with the auxiliary grip to prevent incongruous hand-arm system positions (code 692039237 - see [Accessories Catalogue no. 79](#)).

Model	Code	Max torque (Nm)	Max charge (Kg)
BC40LK	692031055	40	5
BC40	692031033	40	2
BCA40	692031037	40	2



Ergonomic grip.

To use with screwdrivers installed on BC and BCA Cartesian Arms.

It allows correct gripping at any point in which the arm can operate, preventing incongruous handarm system positions.

The grip can be installed on the right or left of the boom, with vertical or horizontal gripping.

In all these positions, **the grip turns around its axis or can be locked, depending on how it needs to be used.**

It has a housing for the screwdriver connector as well as a lever to load and shoot screws.

Model	Code
Grip for auto feed screwdrivers	692039237



Supporting structures and hoppers.

Entirely designed and manufactured by Fiam, they serve to support EasyDriver feeders and their hoppers when used to meet the need for fast production rhythms. They ensure greater cleanliness and functionality of the operational layout, thanks to:

- An **aluminium base plate complete with holes** for fastening to the feeder
- **Hollow aluminium profiles that allow cables and tube bundles to pass** under the supporting surface
- **Supporting feet with adjustable height** and the option of anchoring to the floor simply with the brackets provided.

Discover the available configurations on page. 39.

For more information about the features refer to the catalogue No. 89:

[CA - Handheld tightening system with automatic screw feeding.](#)

Technical specifications for MCA auto feed tightening modules.

	Type of nutrunner model	Torque range of nutrunner motor eTensil		Idle speed	Control unit	EasyDriver screw feeder	Fastening slide
	Model	Nm	in lb	Min. / Max.	Type	Type	Type
WITH FASTENING SLIDE	MCA E8MCC S.../D... C1/C3...	0,3 ÷ 7	2.6 ÷ 61.9	55 ÷ 2000	TPU-C1 TPU-C3	ED B ED B 1 1 ED B M 1 1 ED B 2 1 ED B 1 2 ED B M 1 2	SM SW DM DW
FOR COBOT	MCA E8MCC AC C1/C3...	0,3 ÷ 7	2.6 ÷ 61.9	55 ÷ 2000	TPU-C1 TPU-C3	ED B ED B 1 1 ED B M 1 1 ED B 2 1 ED B 1 2 ED B M 1 2	stroke: 100 mm

Reversibility	Starting system	
<p> Non-reversible nutrunner motor (only tightening)</p> <p>Tightening module MCA</p> <p>Type of nutrunner motor E8MCC</p> <p>Type of fastening slide SM SW DM DW</p> <p>Tightening device AC</p> <p>Type of control units C1 = TPU-C1 - Control unit eTensil C3 = TPU-C3 - Control unit eTensil</p> <p>Type of screw feeders B = Easy Driver ED B B11 = Easy Driver ED B 1 1 BM11 = Easy Driver ED B M 1 1 B21 = Easy Driver ED B 2 1 B12 = Easy Driver ED B 1 2 BM12 = Easy Driver ED B M 1 2</p>	Remote start	<p>• Accessory drive: female hexagonal drive 1/4", 6,35 mm (ISO 1173).</p> <p>Torque values refer to analysis of laboratory performing tests that comply with the standard ISO 5393 with screwdriver set at to the maximum speed and should be considered as indicative. The values in real applications can be influenced by many factors such as, for example: joint (type of joint, degree of elasticity), screw (type and length), accessory used (type or length of the blade), tightening speed, assembly conditions (free standing screwdriver, screwdriver mounted on a torque arm), operator behavior during the tightening phase.</p> <p>For any further details, please address to Fiam Technical Service.</p>
		<p>All nutrunner motors are supplied with a working speed equal to 25% of the nominal one to guarantee tightening quality and precision.</p> <p>In order to obtain the nominal torque and speed range, it is necessary to set parameters following the instructions given in Use and Maintenance Manual.</p> <p>For any further information, contact the Fiam Technical Service.</p>

Standard equipment (supplied with MCA module with FASTENING SLIDE)

- EasyDriver feeder choosen
- Electric nutrunner motor
- Selected control unit and connection cable
- 4 tightening bits (1 fitted + 3 spares)
- Ethernet connection cable
- Fastening slide complete with pneumatic fittings and supporting bracket
- Screw-retaining head customized for the screw, completed with bush
- Screw shooting hose
- Two shielded screw transit sensor
- Operation and maintenance manual
- Eco-friendly packaging (weight kg 3), dimensions: mm L 600 x 450 x h 520

Standard equipment (supplied with MCA module for COBOT)

- EasyDriver feeder choosen
- Electric nutrunner motor with forward bit stroke device
- Selected control unit and connection cable
- 4 tightening bits (1 fitted + 3 spares)
- Ethernet connection cable
- Screw shooting hose
- Two shielded screw transit sensors
- Operation and maintenance manual
- Eco-friendly packaging, dimensions: mm L 600 x 450 x h 520

The supply does not include the brachet for fixing the forward bit stroke device to the Cobot.

Control unit technical features.

Model	Code	Speed	Nr. of connectable tools	Tool feed tension	Feed input	I/O	Visual indicators	Weight kg	L x Width x H mm
TPU-C1	686200105	Adjustable	1	32 VDC	230 Vac ±10% 50-60 Hz	8 inputs 8 outputs 9 + 11 signal types	7 LED DISPLAY	0,8	185x150x105
TPU-C3	686200107	Adjustable	1	32 VDC	230 Vac ±10% 50-60 Hz	8 inputs 8 outputs 21 + 22 signal types	7 LED DISPLAY	0,8	185x150x105
TPU-C1-120V	686200106	Adjustable	1	32 VDC	120 Vac ±10% 50-60 Hz	8 inputs 8 outputs 9 + 11 signal types	7 LED DISPLAY	0,8	185x150x105
TPU-C3-120V	686200108	Adjustable	1	32 VDC	120 Vac ±10% 50-60 Hz	8 inputs 8 outputs 21 + 22 signal types	7 LED DISPLAY	0,8	185x150x105

Standard equipment

- Control unit are fitted with cable and European plug (TPU-C1 and TPU-C3), American plug (TPU-C1-120V and TPU-C3-120V)
- Use and maintenance manual
- Eco-friendly packaging
- The unit is equipped with adjustable tilt foot

Accessories available upon request

- **Fixing plate to position** the power supply unit on any surface. It is supplied complete with screws, and can be anchored vertically or on a horizontal support (code 692080000)
- **Signal lights and various accessories for control unit:** see p. 17
- **Fiam HyperTerminal** kit to manage tightening results: see p. 19
- **Multiple connector for I/O**, code 692076193. With MCA autofeed tightening module, where TPU unit I/O port is used for connection to the screw feeder, to have additional connection, e.g. with PLC Master to have programs selection, the Multiple connector for I/O is required. See page 18.



eTensil screwdrivers, nutrunner motors and TPU control units, are covered by an extended warranty of 24 months or 1.000.000 cycles (first goal achieved).

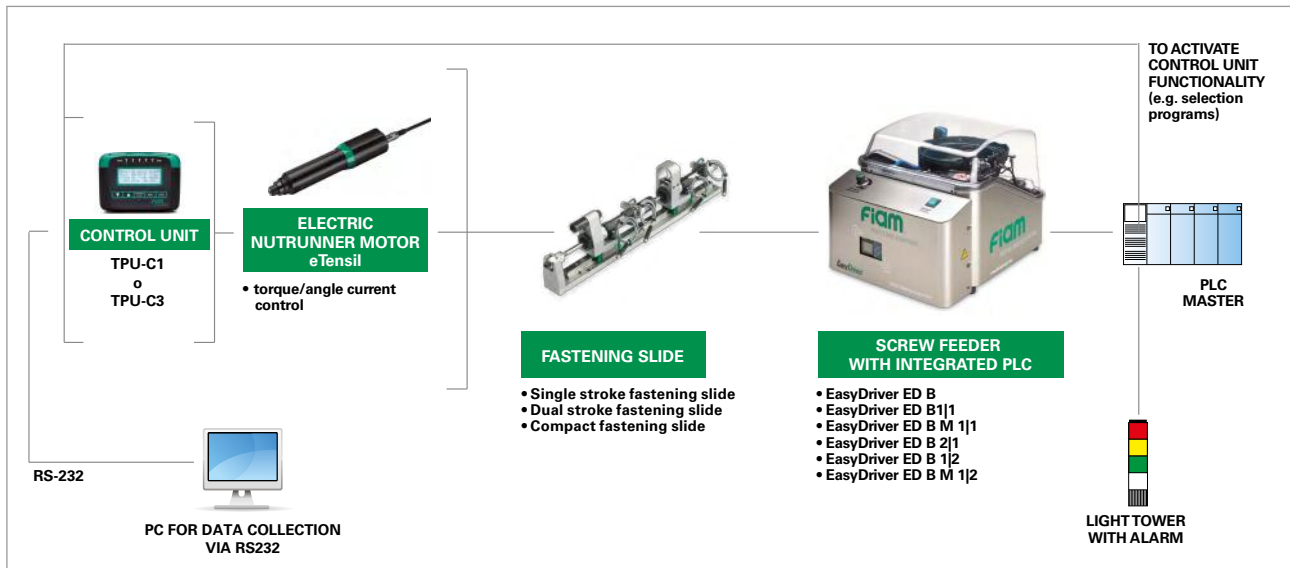

EasyDriver feeders for tightening modules.

Feeders that can be used with MCA modules are of different types:

EasyDriver ED B (1 x 240mm Ø bowl feeds 1 slide/spindle)

Feeds the screws optimally and without jamming.

For screws between 10 and 35 mm in length.

EasyDriver ED B 1|1 (1 x 240mm Ø bowl feeds 1 slide/spindle).

Feeds the screws optimally and without jamming and used when greater soundproofing is required.

For screws between 10 and 35 mm in length.

EasyDriver ED B M 1|1 (MAXI 1|1 = 420mm Ø bowl feeds 1 slide/spindle). Used when the job involves large screws and also in the event of high production rates to allow the system to run unaided for longer. For screws between 35 and 60 mm in length.

EasyDriver ED B 2|1 (2|1 = 2 240mm Ø bowls feed 1 slide/spindle). With its dual circular bowls, it can process 2 geometrically similar screws, for example differing in length or made from different materials (e.g. stainless steel / browned steel) to feed a slide (one way). Screw choice is managed by the feeder's PLC through a selector or by an external signal. For screws between 10 and 35 mm in length.

EasyDriver ED B 1|2 (1 x 240mm Ø bowl feeds 2 slides/spindles). Designed to feed two single- or dual-stroke slides. The work cycle involves selecting and shooting 2 screws at the same time. For screws between 10 and 35 mm in length.

EasyDriver ED B M 1|2 (1 x 420mm Ø bowl feeds 2 slides/spindles). Used when the job involves large screws and there is the need to feed two single- or dual-stroke slides. The work cycle involves selecting and shooting 2 screws at the same time. For screws between 35 and 60 mm in length.

For more information about the features refer to the catalogue No. 73:

MCA-Tightening module to be integrated into automatic production systems.



Fastening slides.

Are **completely designed by Fiam** who also takes care of their construction. They are equipped with:

- **Shielded screw transit sensor** even monitors very small screws
- **Practical and rational hose** that includes cables between slide and feeder
- **Pneumatic cylinders** equipped with built-in air decelerators.

The models available are:

- **SM - SINGLE STROKE**: this fastening slide stands out for the single stroke performed by its motor to reach the tightening point and then tighten. Considering compact dimensions and weight, single stroke fastening slides are particularly suitable in situations where the approach movement is made by a robot arm or a manipulator with Z axis.
- **DM - DUAL STROKE**: in addition to the stroke performed by the motor for the purpose of tightening, they feature an additional approach stroke to bring the head down to the component.
- **DUAL STROKE WITH OFF-SET DEVICE**: in addition to the stroke performed by the motor for the purpose of tightening, these slides feature an additional approach stroke to bring the head down to the component, as well as the offset device, which enables you to reach tightening points with very short centre-to-centre distances.

“Screw at sight” function

Fastening slide can be supplied with this function: the screw is held firmly inside the screw-retaining head and screw engagement movement is achieved by means of an additional cylinder. Once the screw has reached the screw-retaining head, the imprint is engaged and then further steps of approach and subsequent tightening can be completed.

Compact configuration

Ideal for working from the bottom to the top and/or for layouts with reduced encumbrances. The configuration also includes the “screw at sight” function which, in addition to allowing greater ease of centering on the tightening point, if used from the bottom up, prevents the screw from falling back to the end of the shot.

For more information about the features refer to the catalogue No. 73:

MCA-Tightening module to be integrated into automatic production systems.



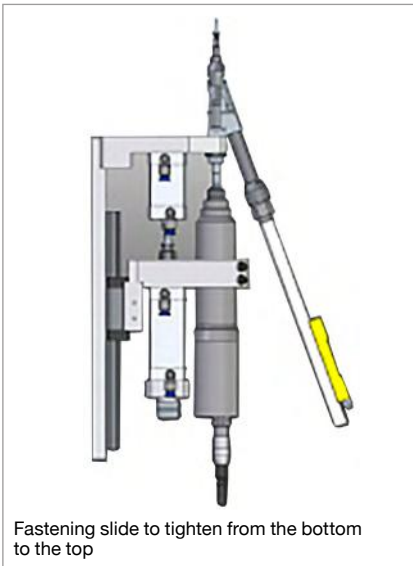

Fastening slide to tighten from the bottom to the top

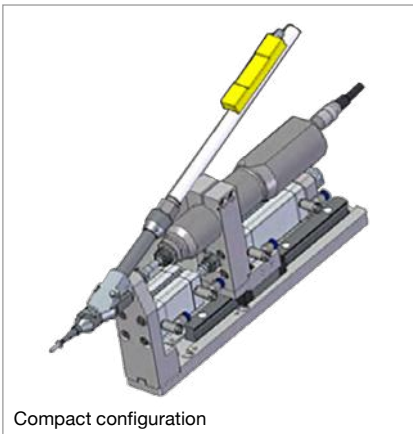

Compact configuration

Single-stroke fastening slide	Size (rail track size)	Tightening and approach strokes	Cylinder Ø (bore)
	mm	mm	mm
SM 15D20 050-00 36	15	50	20
SM 15D20 080-00 36	15	80	20
SM 15D25 050-00 36	15	50	25
SM 15D25 080-00 36	15	80	25

Dual-stroke fastening slide	Size (rail track size)	Tightening and approach strokes	Cylinder Ø (bore)
	mm	mm	mm
DM 15D20 050-50 36	15	50-50	20
DM 15D20 050-80 36	15	50-80	20
DM 15D20 080-50 36	15	80-50	20
DM 15D20 080-80 36	15	80-80	20
DM 15D25 050-50 36	15	50-50	25
DM 15D25 050-80 36	15	50-80	25
DM 15D25 080-50 36	15	80-50	25
DM 15D25 080-80 36	15	80-80	25

How to read model names

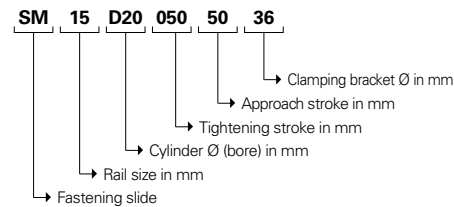

Screw-retaining heads (nose piece).

They are completely customized to the customer's needs. All equipped with a mechanical grip which ensures perfect retention of the screw on the head and represent an excellent alternative to screw suction systems that can become inefficient in the case of assemblies on materials that create dust during tightening. Available with:

- **With anti-overturning device** for screws with length/head diameter ratio between 1.1 (approx.) And 1.5. To prevent screw jamming
- **With friction jaws** holding the screw on the head and not on the stem: jaws do not open, allowing screw insertion into holes
- **For big screws** to tighten screws up to 45 mm length
- **With hose** to reach embedded tightening points or inside holes
- **With support or protective spacer/special materials** to ease the positioning on the components and to avoid damaging them during assembly
- **With elastic hose and mechanical screw gripping.** The hose not only holds the screw perfectly on the head but it rotates together with the screw during tightening. Ideal situation for embedded tightening points.

For more information about the features refer to the catalogue No. 73:

[MCA-Tightening module to be integrated into automatic production systems.](#)



Supporting structures and hoppers.

Entirely designed and manufactured by Fiam, they are useful to support EasyDriver feeders and their hoppers when used to solve needs production at high rates.

They ensure greater cleanliness and functionality of the operational layout thanks to:

- An **aluminum base plate already prepared with the holes** that allow to fix the suitable feeder on it
- **Aluminum profiles with channels for cables and tube bundles inside the slots** positioned under the support surface
- **Support adjustable feet in height** and possibility of having additional brackets for floor fixing through a simple anchoring with supplied squares.

Per approfondire le caratteristiche, consultare il catalogo 73: [MCA - Modulo di avvitatura da integrare su sistemi produttivi automatici.](#)

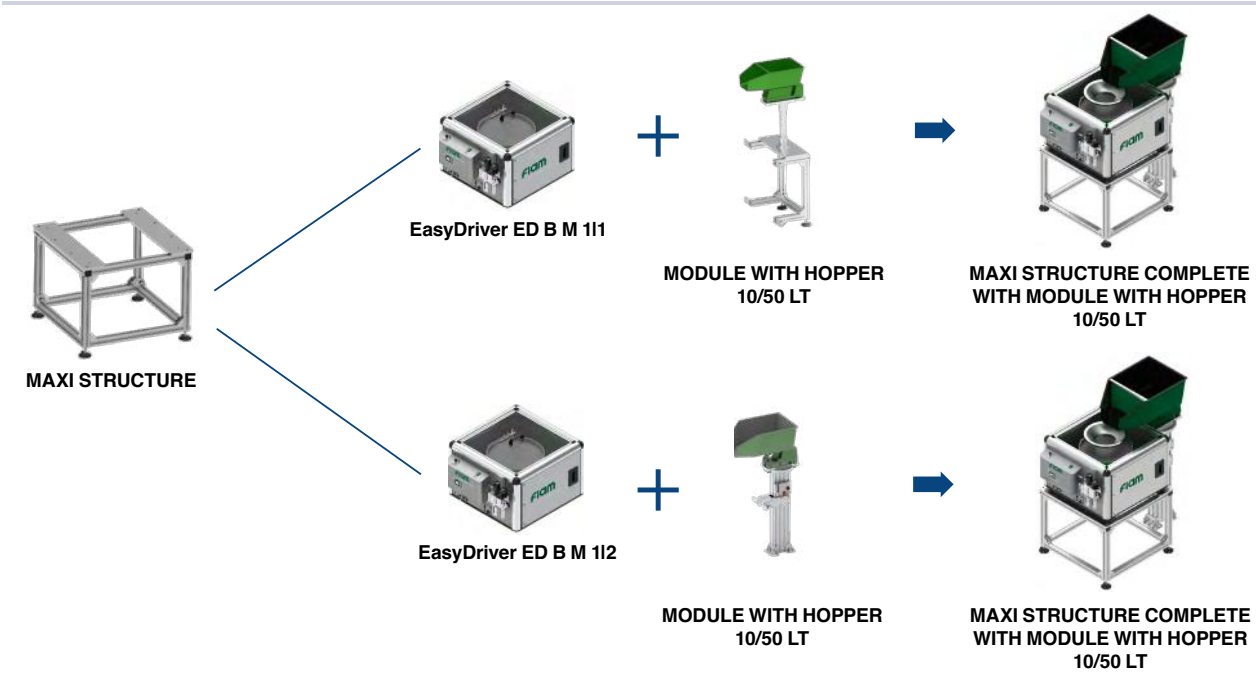
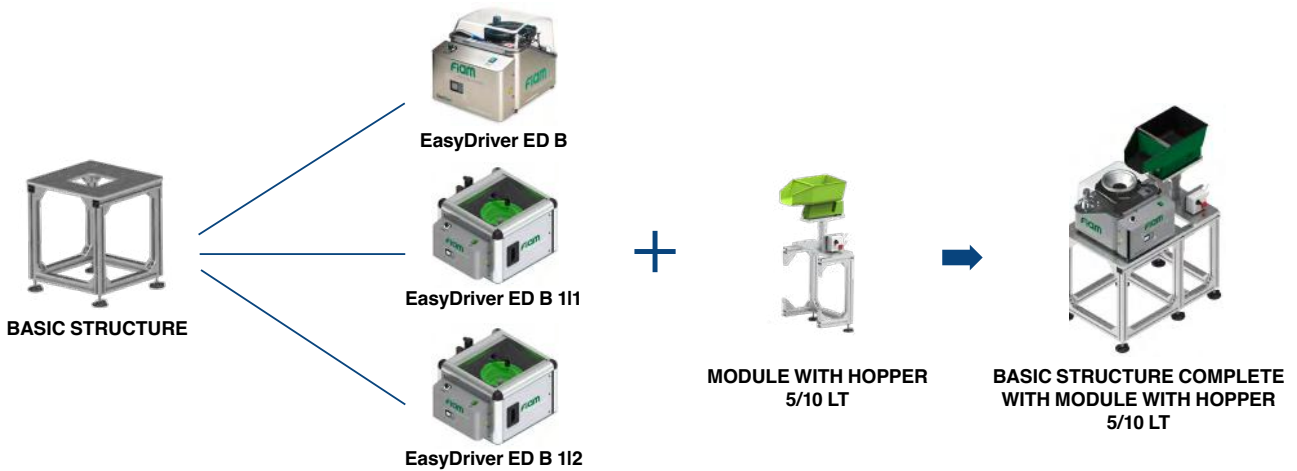



REQUEST A FREE QUOTATION!

By sending us the details through Data Entry 4.0 configurator, **which you can compile directly on our website**, you will quickly receive a no-obligation "turnkey" solution that will save you time and money!

<https://www.fiamgroup.com/en/request-a-quotation/>



<https://www.fiamgroup.com/en/etensil-the-fiam-electrical-revolution/>



**Fiam Utensili
Pneumatici Spa**
Viale Crispi 123
36100 Vicenza - Italy
Tel. +39 0444.385000
Fax +39 0444.385002
www.fiamgroup.com
info@fiamgroup.com

**Fiam France
Succursale**
73, cours Albert Thomas
69003 Lyon - France
Tel. +33 (0)9 70 40 73 85

**Fiam España
Sucursal**
Travessera de Gràcia, 11,
5ª planta
08021 Barcelona - España
Tel. +34 636808112

Meet us on   



Quality Management
System Certificate



Environmental Management
System Certificate